

Model: ZR12M3E-TWD

Data

Type: Hermetic piston compressors

Producer: Copeland

Series: ZR

Model: ZR12M3E-TWD

Technical data

Nominal motor power [HP]:	10
Displacement [m ³ /h]:	28,8
Sound pressure level :	67
Gross/Net weight [kg]:	111/100
Oil charge [dm ³]:	4,1

Electrical data

Power supply [V/~/Hz]:	380-420/3/50Hz
Locked rotor current [A]:	127
Max. operating current [A]:	22
Winding resistance [Ω]:	1,02

Connections

	<u>milimeters</u>	<u>inches</u>
Suction Rotolock valve connection:		1 3/4"
Discharge Rotolock valve connection:		1 1/4"
Suction connection with supplied sleeve:		1 3/8"
Discharge connection with supplied sleeve:		7/8"

Model: ZR12M3E-TWD

Capacity

R22

Cooling capacity [kW]

$t_c \setminus t_e$	-20	-15	-10	-5	0	5	10	15
20	13.44	16.77	20.60	25.03	30.14	36.03	-	-
25	12.86	16.14	19.89	24.19	29.13	34.82	41.34	-
30	12.22	15.44	19.09	23.26	28.04	33.51	39.78	46.94
35	11.51	14.68	18.23	22.26	26.86	32.12	38.14	45.00
40	10.75	13.85	17.30	21.19	25.61	30.66	36.42	42.99
45	-	12.98	16.32	20.07	24.30	29.13	34.63	40.90
50	-	-	15.30	18.89	22.94	27.54	32.77	38.74
55	-	-	-	17.68	21.54	25.90	30.87	36.53
60	-	-	-	-	20.09	24.22	28.92	34.26
65	-	-	-	-	18.62	22.51	26.93	31.96

Power input [kW]

$t_c \setminus t_e$	-20	-15	-10	-5	0	5	10	15
20	4.35	4.37	4.38	4.40	4.43	4.49	-	-
25	4.87	4.90	4.90	4.90	4.91	4.94	5.01	-
30	5.43	5.47	5.48	5.47	5.46	5.47	5.50	5.57
35	6.02	6.07	6.09	6.09	6.07	6.06	6.07	6.10
40	6.64	6.73	6.76	6.77	6.76	6.73	6.72	6.73
45	-	7.42	7.49	7.51	7.51	7.49	7.46	7.45
50	-	-	8.27	8.32	8.33	8.31	8.29	8.27
55	-	-	-	9.19	9.23	9.23	9.21	9.18
60	-	-	-	-	10.20	10.22	10.22	10.20
65	-	-	-	-	11.25	11.31	11.32	11.32

Model: ZR12M3E-TWD

Capacity

Current [A]

$t_c \setminus t_e$	-20	-15	-10	-5	0	5	10	15
20	11.38	11.42	11.43	11.45	11.49	11.57	-	-
25	11.85	11.88	11.89	11.88	11.89	11.93	12.02	-
30	12.36	12.41	12.42	12.40	12.39	12.40	12.45	12.56
35	12.94	13.02	13.03	13.02	13.00	12.98	13.00	13.07
40	13.59	13.70	13.74	13.74	13.71	13.69	13.68	13.72
45	-	14.47	14.54	14.56	14.55	14.52	14.51	14.52
50	-	-	15.45	15.50	15.51	15.49	15.47	15.48
55	-	-	-	16.55	16.59	16.60	16.59	16.59
60	-	-	-	-	17.81	17.85	17.87	17.87
65	-	-	-	-	19.18	19.26	19.30	19.33

Mass flow [kg/s]

$t_c \setminus t_e$	-20	-15	-10	-5	0	5	10	15
20	268.16	331.22	402.20	482.81	574.79	679.83	-	-
25	265.93	330.04	401.70	482.63	574.53	679.13	798.14	-
30	262.22	327.36	399.68	480.88	572.69	676.82	794.99	928.91
35	257.13	323.27	396.22	477.68	569.36	673.00	790.29	922.97
40	250.75	317.87	391.42	473.10	564.64	667.75	784.15	915.55
45	-	311.25	385.37	467.25	558.62	661.18	776.65	906.75
50	-	-	378.18	460.23	551.39	653.38	767.90	896.67
55	-	-	-	452.13	543.06	644.44	757.99	885.41
60	-	-	-	-	533.72	634.47	747.01	873.05
65	-	-	-	-	523.47	623.56	735.06	859.70

Model: ZR12M3E-TWD

Capacity

C.O.P. [W/W]

$t_c \setminus t_e$	-20	-15	-10	-5	0	5	10	15
20	3.09	3.84	4.70	5.69	6.81	8.03	-	-
25	2.64	3.30	4.05	4.93	5.93	7.05	8.26	-
30	2.25	2.83	3.49	4.25	5.13	6.13	7.24	8.43
35	1.91	2.42	2.99	3.66	4.42	5.30	6.29	7.37
40	1.62	2.06	2.56	3.13	3.79	4.55	5.42	6.39
45	-	1.75	2.18	2.67	3.24	3.89	4.64	5.49
50	-	-	1.85	2.27	2.75	3.31	3.95	4.68
55	-	-	-	1.92	2.33	2.81	3.35	3.98
60	-	-	-	-	1.97	2.37	2.83	3.36
65	-	-	-	-	1.65	1.99	2.38	2.82

Application range

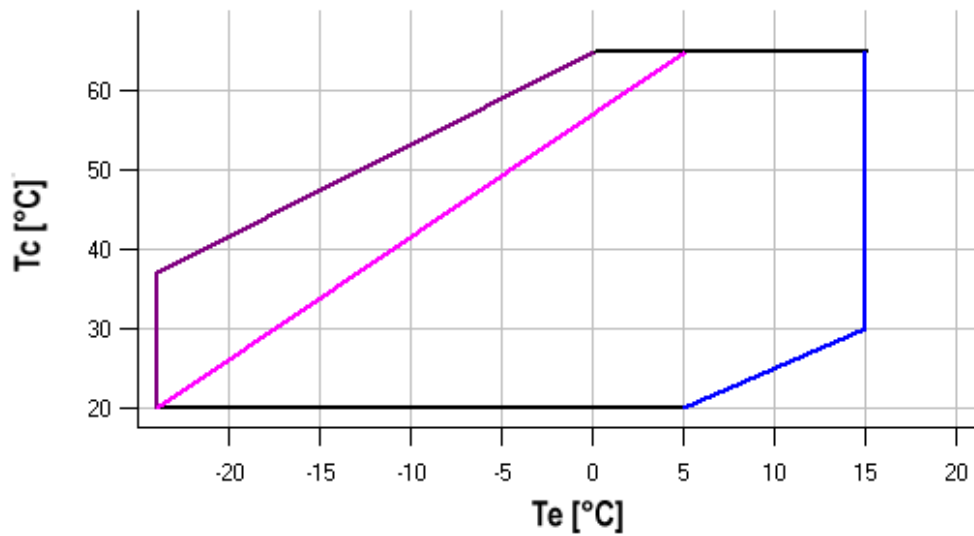

- Maximum evaporating temperature
- 25°C suction gas temperature
- 10K gas overheat

Operating conditions: 10K suction superheat, 0K subcooling

t_c - Condensing temperature [°C]

t_e - Evaporating temperature [°C]

Model: ZR12M3E-TWD

Capacity

R134a

Cooling capacity [kW]

$t_c \setminus t_e$	-15	-10	-5	0	5	10	15
30	9.43	11.92	14.93	18.47	22.57	27.28	32.61
35	8.96	11.34	14.21	17.62	21.58	26.13	31.30
40	8.49	10.73	13.47	16.72	20.52	24.90	29.89
45	8.03	10.12	12.69	15.78	19.40	23.59	28.39
50	-	9.51	11.91	14.81	18.24	22.23	26.81
55	-	-	11.13	13.82	17.04	20.81	25.16
60	-	-	10.36	12.83	15.83	19.36	23.46
65	-	-	-	11.86	14.60	17.88	21.73
70	-	-	-	-	13.39	16.40	19.96

Power input [kW]

$t_c \setminus t_e$	-15	-10	-5	0	5	10	15
30	3.64	3.71	3.78	3.84	3.89	3.93	3.96
35	4.06	4.14	4.20	4.26	4.30	4.33	4.35
40	4.52	4.60	4.67	4.73	4.76	4.79	4.80
45	5.00	5.10	5.18	5.24	5.29	5.32	5.33
50	-	5.63	5.73	5.81	5.87	5.91	5.93
55	-	-	6.31	6.42	6.50	6.55	6.59
60	-	-	6.93	7.06	7.17	7.25	7.31
65	-	-	-	7.74	7.89	8.00	8.09
70	-	-	-	-	8.65	8.80	8.93

Model: ZR12M3E-TWD

Capacity

Current [A]

$t_c \setminus t_e$	-15	-10	-5	0	5	10	15
30	10.60	10.62	10.62	10.64	10.69	10.80	10.97
35	10.95	10.97	10.97	10.98	11.01	11.09	11.23
40	11.36	11.39	11.40	11.40	11.42	11.48	11.59
45	11.84	11.88	11.90	11.90	11.92	11.96	12.04
50	-	12.46	12.49	12.50	12.51	12.54	12.61
55	-	-	13.17	13.19	13.21	13.23	13.29
60	-	-	13.94	13.99	14.01	14.04	14.09
65	-	-	-	14.89	14.93	14.96	15.01
70	-	-	-	-	15.96	16.01	16.07

Mass flow [kg/s]

$t_c \setminus t_e$	-15	-10	-5	0	5	10	15
30	218.08	270.37	331.76	402.44	482.57	572.35	671.95
35	217.79	269.64	330.92	401.81	482.48	573.12	673.91
40	217.48	268.55	329.37	400.12	480.98	572.14	673.77
45	217.41	267.35	327.37	397.64	478.35	569.68	671.80
50	-	266.30	325.17	394.62	474.83	565.98	668.26
55	-	-	323.04	391.32	470.69	561.33	663.41
60	-	-	321.24	388.01	466.19	555.96	657.51
65	-	-	-	384.93	461.58	550.14	650.81
70	-	-	-	-	457.12	544.14	643.57

Model: ZR12M3E-TWD

Capacity

C.O.P. [W/W]

$t_c \setminus t_e$	-15	-10	-5	0	5	10	15
30	2.59	3.21	3.95	4.81	5.81	6.94	8.23
35	2.21	2.74	3.38	4.14	5.02	6.04	7.20
40	1.88	2.33	2.88	3.54	4.31	5.20	6.22
45	1.61	1.98	2.45	3.01	3.67	4.44	5.32
50	-	1.69	2.08	2.55	3.11	3.76	4.52
55	-	-	1.76	2.15	2.62	3.18	3.82
60	-	-	1.50	1.82	2.21	2.67	3.21
65	-	-	-	1.53	1.85	2.23	2.68
70	-	-	-	-	1.55	1.86	2.24

Application range

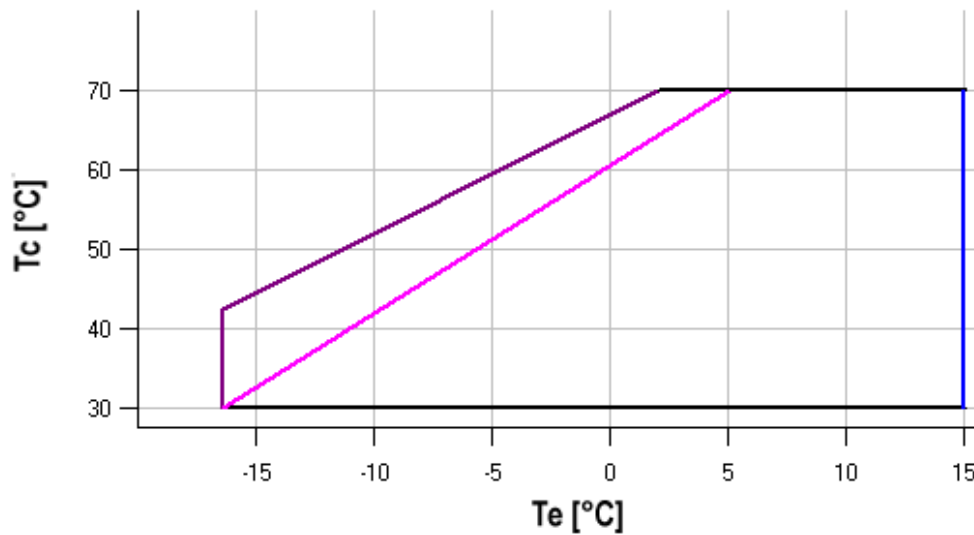

- Maximum evaporating temperature
- 25°C suction gas temperature
- 10K gas overheat

Operating conditions: 10K suction superheat, 0K subcooling

t_c - Condensing temperature [°C]

t_e - Evaporating temperature [°C]

Model: ZR12M3E-TWD

Capacity

R407C

Cooling capacity [kW]

t_c \ t_e	-20	-15	-10	-5	0	5	10	15
10	14.55	17.99	22.07	26.88	-	-	-	-
15	13.86	17.20	21.17	25.83	31.26	-	-	-
20	13.16	16.40	20.24	24.74	29.99	36.07	-	-
25	12.45	15.58	19.28	23.62	28.69	34.55	41.29	-
30	11.73	14.75	18.30	22.48	27.34	32.98	39.47	46.89
35	10.99	13.89	17.30	21.30	25.96	31.37	37.61	44.74
40	10.23	13.00	16.26	20.08	24.54	29.72	35.69	42.54
45	-	12.10	15.20	18.83	23.08	28.02	33.72	40.28
50	-	-	14.10	17.54	21.57	26.27	31.70	37.95
55	-	-	-	16.22	20.02	24.46	29.62	35.57
60	-	-	-	-	18.43	22.61	27.48	33.12
65	-	-	-	-	-	20.70	25.29	30.61

Power input [kW]

t_c \ t_e	-20	-15	-10	-5	0	5	10	15
10	3.41	3.37	3.37	3.45	-	-	-	-
15	3.83	3.77	3.73	3.75	3.85	-	-	-
20	4.28	4.22	4.16	4.13	4.17	4.30	-	-
25	4.76	4.72	4.66	4.61	4.59	4.65	4.81	-
30	5.27	5.27	5.23	5.16	5.12	5.12	5.20	5.39
35	5.80	5.86	5.86	5.80	5.74	5.71	5.72	5.83
40	6.35	6.49	6.54	6.52	6.47	6.41	6.39	6.43
45	-	7.16	7.28	7.31	7.29	7.23	7.19	7.18
50	-	-	8.07	8.18	8.20	8.16	8.11	8.08
55	-	-	-	9.11	9.19	9.20	9.17	9.12
60	-	-	-	-	10.27	10.34	10.34	10.31
65	-	-	-	-	-	11.58	11.63	11.63

Model: ZR12M3E-TWD

Capacity

Current [A]

$t_c \setminus t_e$	-20	-15	-10	-5	0	5	10	15
10	9.67	9.87	10.07	10.30	-	-	-	-
15	10.09	10.25	10.38	10.53	10.73	-	-	-
20	10.55	10.69	10.78	10.87	10.98	11.15	-	-
25	11.06	11.19	11.26	11.31	11.36	11.44	11.60	-
30	11.63	11.77	11.84	11.86	11.87	11.89	11.96	12.11
35	12.25	12.43	12.51	12.53	12.51	12.49	12.50	12.56
40	12.94	13.17	13.29	13.32	13.30	13.25	13.21	13.22
45	-	14.00	14.17	14.24	14.23	14.17	14.11	14.07
50	-	-	15.17	15.29	15.31	15.27	15.20	15.13
55	-	-	-	16.48	16.55	16.54	16.49	16.41
60	-	-	-	-	17.95	18.00	17.97	17.91
65	-	-	-	-	-	19.64	19.66	19.63

Mass flow [kg/s]

$t_c \setminus t_e$	-20	-15	-10	-5	0	5	10	15
10	258.08	316.67	384.16	461.84	-	-	-	-
15	256.55	315.03	382.42	460.02	549.11	-	-	-
20	254.29	312.69	380.03	457.60	546.68	648.57	-	-
25	251.31	309.68	377.00	454.58	543.69	645.63	761.68	-
30	247.62	305.99	373.34	450.96	540.14	642.18	758.35	889.94
35	243.22	301.62	369.04	446.75	536.04	638.21	754.53	886.30
40	238.11	296.60	364.11	441.95	531.39	633.73	750.25	882.24
45	-	290.91	358.57	436.57	526.20	628.75	745.51	877.75
50	-	-	352.40	430.61	520.47	623.27	740.30	872.85
55	-	-	-	424.08	514.21	617.30	734.65	867.53
60	-	-	-	-	507.42	610.84	728.54	861.80
65	-	-	-	-	-	603.90	721.99	855.66

Model: ZR12M3E-TWD

Capacity

C.O.P. [W/W]

$t_c \setminus t_e$	-20	-15	-10	-5	0	5	10	15
10	4.26	5.34	6.55	7.78	-	-	-	-
15	3.62	4.57	5.68	6.89	8.11	-	-	-
20	3.07	3.89	4.86	5.99	7.19	8.39	-	-
25	2.61	3.30	4.14	5.13	6.25	7.43	8.59	-
30	2.23	2.80	3.50	4.35	5.34	6.45	7.60	8.70
35	1.89	2.37	2.95	3.67	4.52	5.50	6.57	7.68
40	1.61	2.00	2.49	3.08	3.79	4.63	5.59	6.62
45	-	1.69	2.09	2.57	3.17	3.87	4.69	5.61
50	-	-	1.75	2.15	2.63	3.22	3.91	4.70
55	-	-	-	1.78	2.18	2.66	3.23	3.90
60	-	-	-	-	1.79	2.19	2.66	3.21
65	-	-	-	-	-	1.79	2.17	2.63

Application range

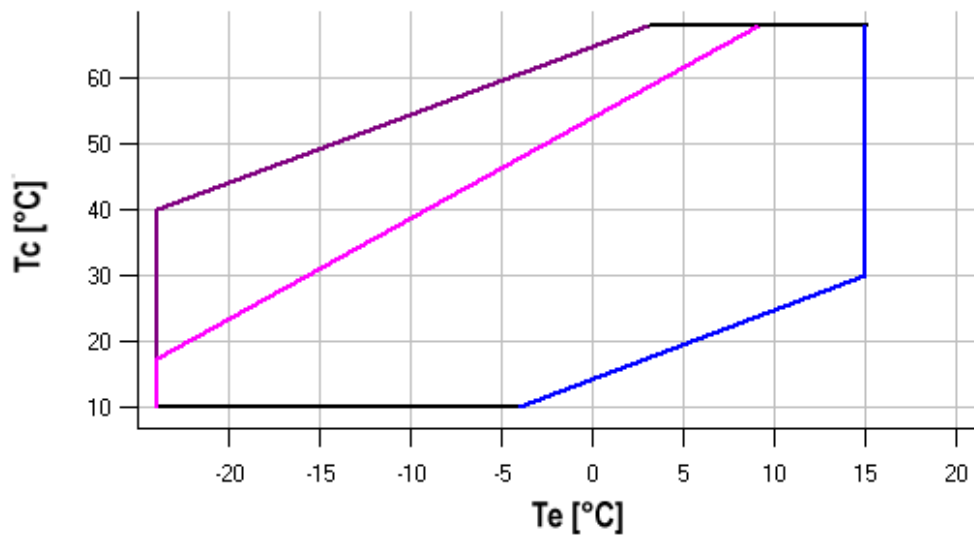

- Maximum evaporating temperature
- 25°C suction gas temperature
- 10K gas overheat

Operating conditions: 10K suction superheat, 0K subcooling

t_c - Condensing temperature [°C]

t_e - Evaporating temperature [°C]

Model: ZR12M3E-TWD

Dimensions

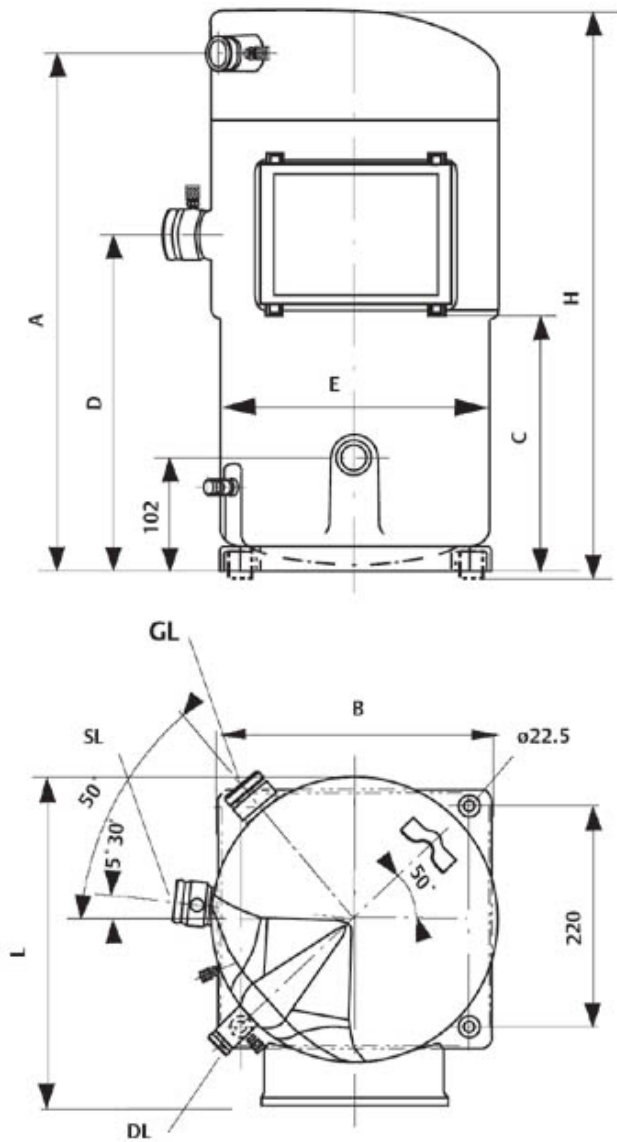

A	497 mm
B	268 mm
C	224 mm
D	318 mm
E	283 mm
H	538 mm
L	360 mm

Model: ZR12M3E-TWD

Image

